

SMART Digital S - DDE

up to 15 l/h

Installation and operating instructions



Further languages

<http://net.grundfos.com/qr/i/95725839>

be
think
innovate

GRUNDFOS 

English (GB) Installation and operating instructions

Original installation and operating instructions

CONTENTS

	Page		Page
1. Safety instructions	2	7.5 Repairs	19
1.1 Symbols used in this document	2	8. Faults	19
1.2 Qualification and training of personnel	2	8.1 Indication of faults	19
1.3 Safety instructions for the operator/user	3	8.2 List of faults	20
1.4 Safety of the system in the event of a failure in the dosing pump	3	9. Disposal	20
1.5 Dosing chemicals	3		
1.6 Diaphragm breakage	4		
2. General information	4		
2.1 Applications	4		
2.2 Improper operating methods	4		
2.3 Symbols on the pump	5		
2.4 Nameplate	5		
2.5 Type key	6		
2.6 Product overview	7		
3. Technical data / Dimensions	7		
3.1 Technical data	7		
3.2 Dimensions	9		
4. Assembly and installation	10		
4.1 Pump assembly	10		
4.1.1 Requirements	10		
4.1.2 Align and install mounting plate	10		
4.1.3 Engage pump in mounting plate	10		
4.2 Hydraulic connection	10		
4.3 Electrical connection	11		
5. Startup	13		
5.1 General notes	13		
5.2 Check before commissioning	13		
5.3 Start and deaerate the pump	13		
6. Operation	13		
6.1 Operating elements	13		
6.2 Operation modes	14		
6.2.1 Manual	14		
6.2.2 Pulse	14		
6.2.3 Change operation modes	14		
6.3 Inputs/outputs	14		
6.3.1 External stop	14		
6.3.2 Empty and low-level signals	14		
6.3.3 Relay outputs	15		
6.3.4 Change settings	15		
7. Service	16		
7.1 Regular maintenance	16		
7.2 Cleaning	16		
7.3 Perform service	16		
7.3.1 Dosing head overview	16		
7.3.2 Dismantling the diaphragm and valves	17		
7.3.3 Reassembling the diaphragm and valves	17		
7.4 Diaphragm breakage	18		
7.4.1 Dismantling in case of diaphragm breakage	18		
7.4.2 Dosing liquid in the pump housing	18		

Warning



Prior to installation, read these installation and operating instructions. Installation and operation must comply with local regulations and accepted codes of good practice.

1. Safety instructions

These installation and operating instructions contain general instructions that must be observed during installation, operation and maintenance of the pump. It must therefore be read by the installation engineer and the relevant qualified operator prior to installation and start-up, and must be available at the installation location at all times.

1.1 Symbols used in this document

Warning



If these safety instructions are not observed, it may result in personal injury.

Caution

If these safety instructions are not observed, it may result in malfunction or damage to the equipment.

Note

Notes or instructions that make the job easier and ensure safe operation.

1.2 Qualification and training of personnel

The personnel responsible for the installation, operation and service must be appropriately qualified for these tasks. Areas of responsibility, levels of authority and the supervision of the personnel must be precisely defined by the operator. If necessary, the personnel must be trained appropriately.

Risks of not observing the safety instructions

Non-observance of the safety instructions may have dangerous consequences for the personnel, the environment and the pump and may result in the loss of any claims for damages.

It may lead to the following hazards:

- Personal injury from exposure to electrical, mechanical and chemical influences.
- Damage to the environment and personal injury from leakage of harmful substances.

1.3 Safety instructions for the operator/user

The safety instructions described in these instructions, existing national regulations on health protection, environmental protection and for accident prevention and any internal working, operating and safety regulations of the operator must be observed. Information attached to the pump must be observed. Leakages of dangerous substances must be disposed of in a way that is not harmful to the personnel or the environment.

Damage caused by electrical energy must be prevented, see the regulations of the local electricity supply company.

Caution

Before starting work on the pump, the pump must be disconnected from the power supply. The system must be pressureless!

Note

The mains plug is the separator separating the pump from the mains.

Only original accessories and original spare parts should be used. Using other parts can result in exemption from liability for any resulting consequences.

1.4 Safety of the system in the event of a failure in the dosing pump

The dosing pump was designed according to the latest technologies and is carefully manufactured and tested.

If it fails regardless of this, the safety of the overall system must be ensured. Use the relevant monitoring and control functions for this.

Caution

Make sure that any chemicals that are released from the pump or any damaged lines do not cause damage to system parts and buildings.

The installation of leak monitoring solutions and drip trays is recommended.

1.5 Dosing chemicals

Warning

Before switching the supply voltage back on, the dosing lines must be connected in such a way that any chemicals in the dosing head cannot spray out and put people at risk.

The dosing medium is pressurised and can be harmful to health and the environment.

Warning

When working with chemicals, the accident prevention regulations applicable at the installation site should be applied (e.g. wearing protective clothing).

Observe the chemical manufacturer's safety data sheets and safety instructions when handling chemicals!



Caution

A deaeration hose, which is routed into a container, e.g. a drip tray, must be connected to the deaeration valve.

Caution

The dosing medium must be in liquid aggregate state!

Observe the freezing and boiling points of the dosing medium!

Caution

The resistance of the parts that come into contact with the dosing medium, such as the dosing head, valve ball, gaskets and lines, depends on the medium, media temperature and operating pressure.

Ensure that parts in contact with the dosing medium are resistant to the dosing medium under operating conditions, see data booklet!

Should you have any questions regarding the material resistance and suitability of the pump for specific dosing media, please contact Grundfos.

1.6 Diaphragm breakage

If the diaphragm leaks or is broken, dosing liquid escapes from the drain opening (fig. 10, pos. 11) on the dosing head. Observe section [7.4 Diaphragm breakage](#).

Warning

Danger of explosion, if dosing liquid has entered the pump housing!

Operation with damaged diaphragm can lead to dosing liquid entering the pump housing.

In case of diaphragm breakage, immediately separate the pump from the power supply!



Make sure the pump cannot be put back into operation by accident!

Dismantle the dosing head without connecting the pump to the power supply and make sure no dosing liquid has entered the pump housing. Proceed as described in section [7.4.1 Dismantling in case of diaphragm breakage](#).

To avoid any danger resulting from diaphragm breakage, observe the following:

- Perform regular maintenance. See section [7.1 Regular maintenance](#).
- Never operate the pump with blocked or soiled drain opening.
 - If the drain opening is blocked or soiled, proceed as described in section [7.4.1 Dismantling in case of diaphragm breakage](#).
- Never attach a hose to the drain opening. If a hose is attached to the drain opening, it is impossible to recognise escaping dosing liquid.
- Take suitable precautions to prevent harm to health and damage to property from escaping dosing liquid.
- Never operate the pump with damaged or loose dosing head screws.

2. General information



The DDE dosing pump is a self-priming diaphragm pump. It consists of a housing with stepper motor and electronics and a dosing head with diaphragm and valves.

Excellent dosing features of the pump:

- Optimal intake even with degassing media, as the pump always works at full suction stroke volume.
- Continuous dosing, as the medium is sucked up with a short suction stroke, regardless of the current dosing flow, and dosed with the longest possible dosing stroke.

2.1 Applications

The pump is suitable for liquid, non-abrasive, non-flammable and non-combustible media strictly in accordance with the instructions in these installation and operating instructions.

Areas of application

- Drinking water treatment
- Wastewater treatment
- Swimming pool water treatment
- Boiler water treatment
- CIP (Clean-In-Place)
- Cooling water treatment
- Process water treatment
- Wash plants
- Chemical industry
- Ultrafiltration processes and reverse osmosis
- Irrigation
- Paper and pulp industry
- Food and beverage industries.

2.2 Improper operating methods

The operational safety of the pump is only guaranteed if it is used in accordance with section [2.1 Applications](#).

Warning



Other applications or the operation of pumps in ambient and operating conditions, which are not approved, are considered improper and are not permitted. Grundfos cannot be held liable for any damage resulting from incorrect use.



Warning





The pump is NOT approved for operation in potentially explosive areas!



Warning

A sunscreen is required for outdoor installation!

2.3 Symbols on the pump

Symbol	Description
	Indication of universally dangerous spot.
	In case of emergency and prior to all maintenance work and repairs, take the mains plug out of the mains supply!
	The device complies with electrical safety class II.
	Connection for deaeration hose at dosing head. If the deaeration hose is not correctly connected, danger will arise due to possible leakage of dosing liquid!

2.4 Nameplate

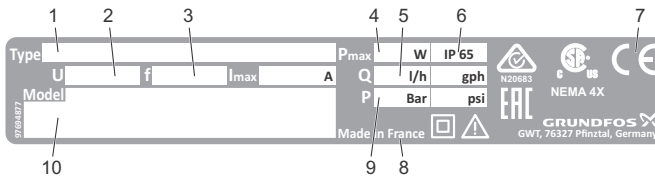

Fig. 1 Nameplate

Pos.	Description	Pos.	Description
1	Type designation	6	Enclosure class
2	Voltage	7	Mark of approval, CE mark, etc.
3	Frequency	8	Country of origin
4	Power consumption	9	Max. operating pressure
5	Max. dosing flow	10	Model

TM04 8144 1716

2.5 Type key

The type key is used to identify the precise pump and is not used for configuration purposes.

Code	Example	DDE	6-	10	P-	PP/	V/	C-	X-	3	1	U2U2	F	G
	Pump type													
	Max. flow [l/h]													
	Max. pressure [bar]													
	Control variant													
B	Basic													
P	B with pulse mode													
PR	P with relay output													
	Dosing head material													
PP	Polypropylene													
PVC	PVC (polyvinyl chloride, only up to 10 bar)													
PV	PVDF (polyvinylidene fluoride)													
SS	Stainless steel DIN 1.4401													
	Gasket material													
E	EPDM													
V	FKM													
T	PTFE													
	Valve ball material													
C	Ceramic													
SS	Stainless steel DIN 1.4401													
	Control cube position													
X	No control cube													
	Voltage													
3	1 x 100-240 V, 50/60 Hz													
	Valve type													
1	Standard													
2	Spring-loaded (HV version)													
	Suction/discharge side connection													
U2U2	Hose, 4/6 mm, 6/9 mm, 6/12 mm, 9/12 mm													
U7U7	Hose 0.17" x 1/4"; 1/4" x 3/8"; 3/8" x 1/2"													
AA	Threaded Rp 1/4", female (stainless steel)													
VV	Threaded 1/4" NPT, female (stainless steel)													
XX	No connection													
	Installation set*													
I001	Hose, 4/6 mm (up to 7.5 l/h, 13 bar)													
I002	Hose, 9/12 mm (up to 60 l/h, 9 bar)													
I003	Hose, 0.17" x 1/4" (up to 7.5 l/h, 13 bar)													
I004	Hose, 3/8" x 1/2" (up to 60 l/h, 10 bar)													
	Mains plug													
F	EU													
B	USA, Canada													
G	UK													
I	Australia, New Zealand, Taiwan													
E	Switzerland													
J	Japan													
L	Argentina													
	Design													
G	Grundfos													

* Including: 2 pump connections, foot valve, injection unit, 6 m PE discharge hose, 2 m PVC suction hose, 2 m PVC deaeration hose (4/6 mm).

2.6 Product overview

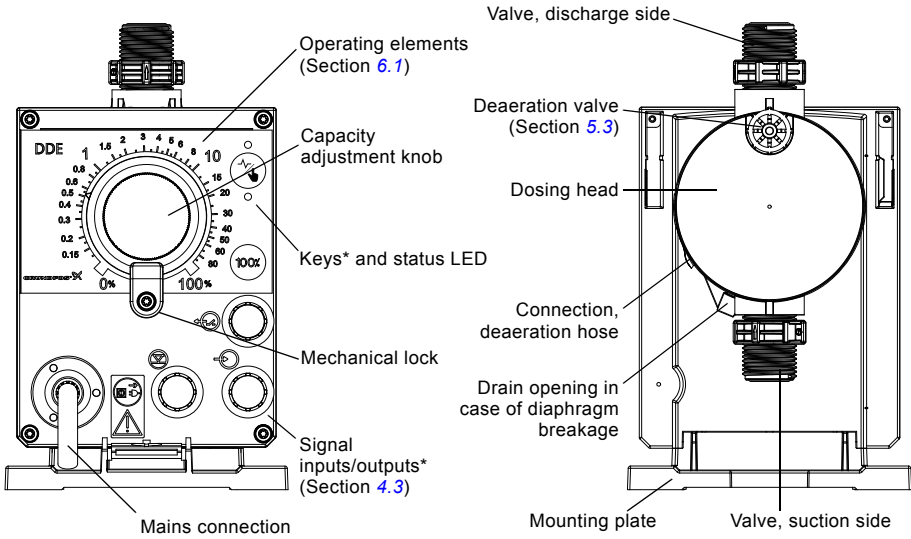

TMD04 1149 3117

* only control variant DDE-PR/P

Fig. 2 Overview

3. Technical data / Dimensions



3.1 Technical data

Data		6-10	15-4	
Mechanical data	Turn-down ratio (setting range)	[1:X]	1000	1000
	Max. dosing capacity	[l/h]	6.0	15.0
		[gph]	1.5	4.0
	Min. dosing capacity	[l/h]	0.006	0.015
		[gph]	0.0015	0.0040
	Max. operating pressure	[bar]	10	4
		[psi]	150	60
	Max. stroke frequency	[strokes/min]	140	180
	Stroke volume	[ml]	0.81	1.58
	Accuracy of repeatability	[%]	± 5	
	Max. suction lift during operation ¹⁾	[m]	6	
	Max. suction lift when priming with wet valves ¹⁾	[m]	2	3
Min. pressure difference between suction and discharge side	[bar]	1		

Data		6-10	15-4	
Mechanical data	Max. inlet pressure, suction side	[bar]	2	
	Max. viscosity with spring-loaded valves ²⁾	[mPas] (= cP)	600	500
	Max. viscosity without spring-loaded valves ²⁾	[mPas] (= cP)	50	
	Min. internal hose/pipe diameter suction/discharge side ^{1), 3)}	[mm]	4	6
	Min. internal hose/pipe diameter suction/discharge side (high viscosity) ³⁾	[mm]	9	
	Min./Max. liquid temperature	[°C]	-10/45	
	Min./Max. ambient temperature	[°C]	0/45	
	Min./Max. storage temperature	[°C]	-20/70	
	Max. relative humidity (non-condensing)	[%]	96	
Max. altitude above sea level	[m]	2000		
Electrical data	Voltage	[V]	100-240 V, - 10 %/+ 10 %, 50/60 Hz	
	Length of mains cable	[m]	1.5	
	Max. inrush current for 2 ms (100 V)	[A]	8	
	Max. inrush current for 2 ms (230 V)	[A]	25	
	Max. power consumption P ₁	[W]	19	
	Enclosure class		IP65, Nema 4X	
	Electrical safety class		II	
Pollution degree		2		
Signal input	Max. load for level input		12 V, 5 mA	
	Max. load for pulse input		12 V, 5 mA	
	Max. load for external stop input		12 V, 5 mA	
	Min. pulse length	[ms]	5	
	Max. pulse frequency	[Hz]	100	
	Max. resistance in level/pulse circuit	[Ω]	1000	
Signal output	Max. ohmic load on relay output	[A]	0.5	
	Max. voltage on relay output	[V]	30 VDC/30 VAC	
Weight/size	Weight (PVC, PP, PVDF)	[kg]	2.4	
	Weight (stainless steel)	[kg]	3.2	
	Diaphragm diameter	[mm]	44	50
Sound pressure	Max. sound pressure level	[dB(A)]	60	
Approvals		CE, CB, CSA-US, NSF61, EAC, ACS, RCM		

1) Data is based on measurements with water

2) Maximum suction lift: 1 m, dosing capacity reduced (approx. 30 %)

3) Length of suction line: 1.5 m, length of discharge line: 10 m (at max. viscosity)

3.2 Dimensions

The indicated dimensions are the same for all control variants of the DDE range.
The following drawing shows the DDE-PR control variant.

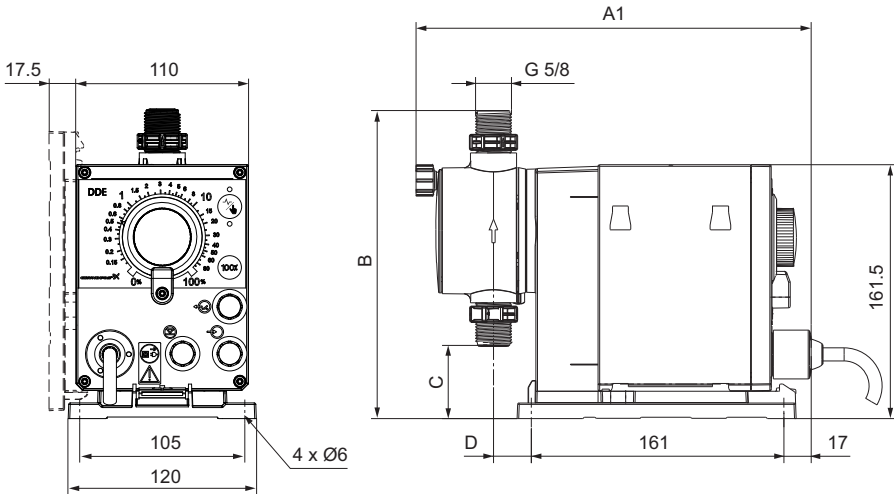

Fig. 3 Dimensional sketch

TM04 1147 3117

Pump type	A1 [mm]	B [mm]	C [mm]	D [mm]
DDE 6-10	251	196	46.5	24
DDE 15-4	251	200.5	39.5	24

4. Assembly and installation

For use in Australia:

Installation of this product must comply with AS/NZS3500!

Note

Certificate of suitability number: CS9431
RCM number: N20683



4.1 Pump assembly

Warning



Install the pump in such a way that the plug can easily be reached by the operator during operation! This will enable the operator to separate the pump from the mains quickly in case of emergency!

The pump is delivered with a mounting plate. The mounting plate can be mounted vertically, e.g. on a wall, or horizontally, e.g. on a tank. It takes just a few quick steps to firmly secure the pump to the mounting plate by means of a slot mechanism. The pump can easily be released from the mounting plate for maintenance.

4.1.1 Requirements

- The mounting surface must be stable and must not vibrate.
- Dosing must flow upwards vertically.

4.1.2 Align and install mounting plate

- **Vertical installation:** Mounting plate slot mechanism must be above.
- **Horizontal installation:** Mounting plate slot mechanism must be opposite the dosing head.
- The mounting plate can be used as a drill template, please see fig. 3 for drill hole distances.

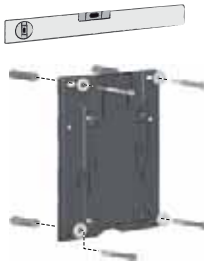

Fig. 4 Locate mounting plate



Warning

Make sure that you do not damage any cables and lines during installation!

1. Indicate drill holes.
2. Drill holes.
3. Secure mounting plate using four screws, diameter 5 mm, to the wall, on the bracket or the tank.

4.1.3 Engage pump in mounting plate

1. Attach the pump to the mounting plate support clamps and slide under slight pressure until it engages.

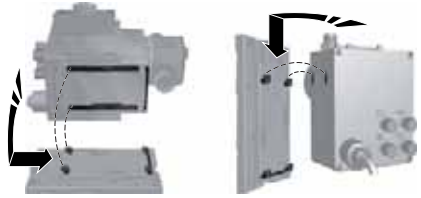

Fig. 5 Engaging the pump

4.2 Hydraulic connection

Warning



Risk of chemical burns!

Wear protective clothing (gloves and goggles) when working on the dosing head, connections or lines!

The dosing head may contain water from the factory check!

Caution

When dosing media which should not come into contact with water, another medium must be dosed beforehand!

Caution

Faultless function can only be guaranteed in conjunction with lines supplied by Grundfos!

Caution

The lines used must comply with the pressure limits as per section [3.1 Technical data](#)!

Important information on installation

- Observe suction lift and hose diameter, see section [3.1 Technical data](#).
- Shorten hoses at right angles.
- Ensure that there are no loops or kinks in the hoses.
- Keep suction line as short as possible.
- Route suction line up towards the suction valve.
- Installing a filter in the suction line protects the entire installation against dirt and reduces the risk of leakage.

TM04 1162 0110

TM04 1159 0110

Hose connection procedure

1. Push union nut and tensioning ring across hose.
2. Push cone part fully into the hose, see fig. 6.
3. Attach cone part with hose to the corresponding pump valve.
4. Tighten union nut manually.
 - Do not use tools!
5. Tighten up union nuts after 2-5 operating hours, if using PTFE gaskets!
6. Attach deaeration hose to the corresponding connection (see fig. 2) and run into a container or a collecting tray.

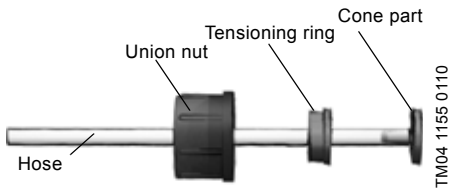

Fig. 6 Hydraulic connection

Note

Pressure differential between suction and discharge side must be at least 1 bar/14.5 psi!

Caution

Tighten the dosing head screws with a torque wrench once before commissioning and again after 2-5 operating hours at 4 Nm.

Installation example

The pump offers various installation options. In the picture below, the pump is installed in conjunction with a suction line, level switch and multifunction valve on a Grundfos tank.



Fig. 7 Installation example

4.3 Electrical connection

Mains connection



Warning

The enclosure class (IP65/Nema 4X) is only guaranteed if plugs or protective caps are correctly installed!



Warning

The pump can start automatically when the mains voltage is switched on!
Do not manipulate mains plug or cable!

The mains plug is the separator separating the pump from the mains.

Note

The rated voltage of the pump, see section 2.4 *Nameplate*, must conform to local conditions.

The pump is supplied with assembled mains cable and plug.

1. Set capacity adjustment knob to 0 % (see 6.1 *Operating elements*).
2. Connect the mains plug with the mains socket.

Signal connections

Applies to DDE-PR/P control variant.

Warning
 Electric circuits of external devices connected to the pump inputs must be separated from dangerous voltage by means of double or reinforced insulation!

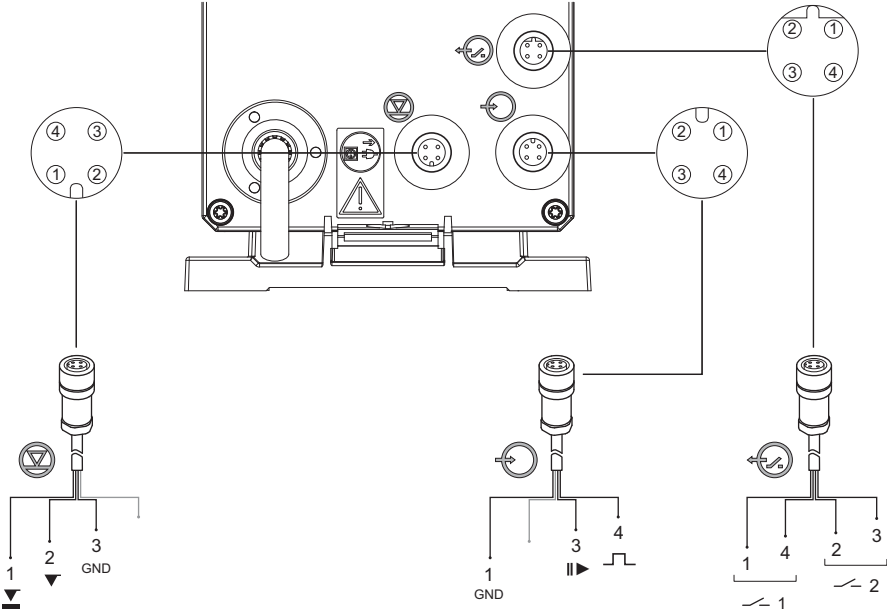

TM04 8172 5111

Fig. 8 Wiring diagram of the electrical connections (DDE-PR/P)

External stop and pulse input

Function	Pins			
	1/brown	2/white	3/blue	4/black
External stop	GND		X	
Pulse	GND			X

Level signals: empty and low-level signal

Function	Pins			
	1	2	3	4
Low-level signal	X		GND	
Empty signal		X	GND	

Relay outputs*

Function	Pins			
	1/brown	2/white	3/blue	4/black
Relay 1 (Alarm)	X			X
Relay 2 (selectable)		X	X	

* applies to DDE-PR control variant

5. Startup



5.1 General notes



Warning

Suction and discharge hoses must be connected correctly!
The deaeration hose must be connected correctly and inserted into a suitable tank!

Caution

Tighten the dosing head screws with a torque wrench once before commissioning and again after 2-5 operating hours at 4 Nm.

5.2 Check before commissioning

- Check that the rated voltage indicated on the nameplate complies with the local conditions.
- Check that all connections are assembled correctly. Tighten connections, if necessary.
- Check that the dosing head screws are tightened with the indicated torque (4 Nm). Tighten dosing head screws, if necessary.
- Check that all electrical cables and plugs are connected correctly.

5.3 Start and deaerate the pump

1. Connect mains supply (see [4.3 Electrical connection](#)).
2. Open the deaeration valve by approximately half a turn.
3. DDE-PR/P control variant: Press the [100%] key and hold it down, until liquid flows out of the deaeration hose continuously and without any bubbles.
4. DDE-B control variant: Turn the capacity adjustment knob to 100 % and wait, until liquid flows out of the deaeration hose continuously and without any bubbles. Then set the capacity adjustment knob back to 0 %.
5. Close the deaeration valve.

The pump is deaerated.

6. Operation



6.1 Operating elements

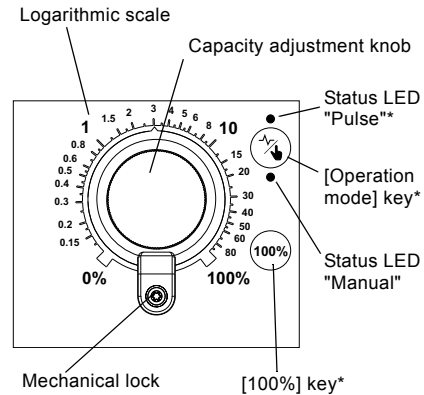

Fig. 9 Operating elements

* Applies to DDE-PR/P control variant.

Capacity adjustment knob

The capacity adjustment knob is used to set the capacity in percent of the maximum dosing flow of the pump. Due to the logarithmical increase of the percent values, even small dosing capacities can be set accurately.

Mechanical lock

The mechanical lock protects the set dosing capacity against unauthorised manipulation. For locking, tighten the screw until the adjustment knob cannot be turned anymore.

Keys and LEDs

Note The DDE-B control variant is only equipped with a status LED.

When pressing and holding down the [100%] key, the pump doses at 100 % for a certain time.

The [100%] key can be used e.g. for deaeration.

The [Operation mode] key is used to change between the "Manual" and "Pulse" mode (see section [6.2.3 Change operation modes](#)).

According to the selected operation mode, the respective status LED is active

("Pulse" = LED above key; "Manual" = LED below key).

TM04 1150 3117

The status LEDs indicate the following operating statuses and faults:

LED colour	Pump status/fault
Green (flashing)	stop
Green	running
Red-green (flashing)	standby (external stopped)*
Yellow	low-level signal*
Red	empty signal, pump stops*
Red (flashing)	motor blocked, pump stops

* only DDE-PR/P control variant

6.2 Operation modes

Following operation modes are available:

- **Manual**, see section [6.2.1 Manual](#)
- **Pulse***, see section [6.2.2 Pulse](#)

* Applies to DDE-PR/P control variant.

6.2.1 Manual

In this operation mode, the pump doses constantly the dosing quantity set by the adjustment knob.

The setting range depends on the pump type:

Type	Setting range [l/h]
DDE 6-10	0.0060 - 6
DDE 15-4	0.0150 - 15

6.2.2 Pulse

Applies to DDE-PR/P control variant.

In this operation mode, the pump doses the set dosing volume for each incoming (potential-free) pulse, e.g. from a water meter. The pump automatically calculates the optimum stroke frequency for dosing the set volume per pulse.

The calculation is based on:

- the frequency of external pulses
- the set stroke volume in percent.

The dosing quantity per pulse is set to a value between 0.1 % and 100 % of the stroke volume using the adjustment knob.

The setting range depends on the pump type:

Type	Setting range [ml/pulse]
DDE 6-10	0.0008 - 0.81
DDE 15-4	0.0016 - 1.58

The frequency of incoming pulses is multiplied by the set dosing volume. If the pump receives more pulses than it can process at the maximum dosing flow, it runs at the maximum stroke frequency in continuous operation. Excess pulses will be ignored.

6.2.3 Change operation modes

Applies to DDE-PR/P control variant.

1. Set adjustment knob to 0 %.
2. Connect mains supply (see section [4.3 Electrical connection](#)).
3. Hold down the [Operation mode] key for at least 5 seconds.

The new operation mode is saved.

6.3 Inputs/outputs

Applies to DDE-PR/P control variant.

6.3.1 External stop

The pump can be stopped via an external contact, e.g. from a control room. When activating the external stop signal, the pump switches from the operating state "Running" into the operating state "Standby". According to the selected operation mode, the respective LED flashes red-green.

6.3.2 Empty and low-level signals

In order to monitor the filling level in the tank, a dual-level sensor can be connected to the pump. The pump responds to the signals as follows:

Sensor signal	Pump status
Low level	<ul style="list-style-type: none"> • LED lights up in yellow • Pump continues running
Empty	<ul style="list-style-type: none"> • LED lights up in red • Pump stops

Caution When the tank is filled up again, the pump restarts automatically!

6.3.3 Relay outputs

Applies to DDE-PR control variant.

The pump can switch two external signals using installed relays. The relays are switched by potential-free pulses. The connection diagram of the relays is shown in section 4.3 [Electrical connection](#).

Relay 1 is allocated with the alarm signals (tank empty, motor blocked) as standard. Relay 2 can be allocated with the following signals:

Relay 2 signal	Description
Low-level signal*	low level in tank
Stroke signal	each full stroke
Pulse input**	each incoming pulse from pulse input

* Default setting



** The correct transmission of incoming pulses can only be guaranteed up to a pulse frequency of 5 Hz.

6.3.4 Change settings

The signal inputs (level signals, external stop) and the relay outputs are configured at the factory as normally open (NO) contacts. They can be re-configured as normally closed (NC) contacts. Relay 2 can be allocated with different signals.

The activated settings are indicated by the status LEDs when the pump is in the setup mode. For entering the setup mode and changing settings, proceed as follows:

1. Set adjustment knob to 0 %.
2. Connect mains supply (see section 4.3 [Electrical connection](#)).
3. Press [100%] key and [Operation mode] key simultaneously and hold them down for at least 5 seconds.
 - The pump switches into setup mode 1. The active setup mode is indicated by the colour of the upper status LED. The current setting is indicated by the colour of the lower status LED.
4. Make the desired settings according to the following table:

		Switch setup modes with [Operation mode] key 		
		Setup mode 1 Green	Setup mode 2* Yellow	Setup mode 3* Red
upper status LED		Green	Yellow	Red
setup mode description		Contact type of signal inputs (low-level, empty and external stop)	Contact type of relay outputs	Allocated signal of Relay 2
Change setting with [100%] key 	lower status LED	Green	NO**	Low-level signal**
		Yellow	NC	stroke signal
		Red	-	pulse input

* Only DDE-PR control variant

** Default setting

5. To exit setup mode, keep [100%] key and [Operation mode] key simultaneously pressed for at least 1 second.

7. Service



In order to ensure a long service life and dosing accuracy, wearing parts such as diaphragms and valves must be regularly checked for signs of wear. Where necessary, replace worn parts with original spare parts made from suitable materials.

Should you have any questions, please contact your service partner.



Warning

Maintenance work must only be carried out by qualified staff.

7.1 Regular maintenance

Interval	Task
Daily	<p>Check, if liquid leaks from the drain opening (fig. 10, pos. 11) and if the drain opening is blocked or soiled. If so, follow the instructions given in section 7.4 <i>Diaphragm breakage</i>.</p> <p>Check, if liquid leaks from the dosing head or valves. If necessary, tighten dosing head screws with a torque wrench at 4 Nm. If necessary, tighten valves and cap nuts, or perform service (see 7.3 <i>Perform service</i>).</p>
Weekly	Clean all pump surfaces with a dry and clean cloth.
Every 3 months	<p>Check dosing head screws. If necessary, tighten dosing head screws with a torque wrench at 4 Nm. Replace damaged screws immediately.</p>
Every 2 years or 8000 operating hours*	Replace diaphragm and valves (see 7.3 <i>Perform service</i>)

* For media which result in increased wear, the service interval must be shortened.

7.2 Cleaning

If necessary, clean all pump surfaces with a dry and clean cloth.

7.3 Perform service

Only spare parts and accessories from Grundfos should be used for maintenance. The usage of non-original spare parts and accessories renders any liability for resulting damages null and void.

Further information about carrying out maintenance can be found in the service kit catalogue on our homepage (www.grundfos.com).

Warning

Risk of chemical burns!

When dosing dangerous media, observe the corresponding precautions in the safety data sheets!

Wear protective clothing (gloves and goggles) when working on the dosing head, connections or lines!

Do not allow any chemicals to leak from the pump. Collect and dispose of all chemicals correctly!



Caution

Before any work to the pump, the pump must be disconnected from the power supply. The system must be pressureless!

7.3.1 Dosing head overview

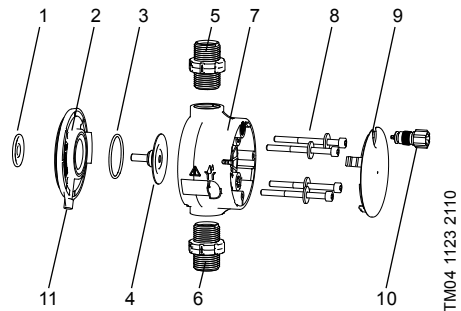

Fig. 10 Dosing head, exploded view

1	Safety diaphragm
2	Flange
3	O-ring
4	Diaphragm
5	Valve on discharge side
6	Valve on suction side
7	Dosing head
8	Screws with discs
9	Cover
10	Deaeration valve
11	Drain opening

TM04 1123 2110

7.3.2 Dismantling the diaphragm and valves

Warning

Danger of explosion, if dosing liquid has entered the pump housing!



If the diaphragm is possibly damaged, don't connect the pump to the power supply! Proceed as described in section [7.4 Diaphragm breakage!](#)

This section refers to fig. [10](#).

1. Make system pressureless.
2. Empty the dosing head before maintenance and flush it, if necessary.
3. Set adjustment knob to 0 %.
4. Switch off mains supply.
5. Take suitable steps to ensure that the returning liquid is safely collected.
6. Dismantle suction, pressure and deaeration hoses.
7. Dismantle valves on suction and discharge side (5, 6).
8. Remove the cover (9).
9. Loosen screws (8) on the dosing head (7) and remove the screws and discs.
10. Remove the dosing head (7).
11. Unscrew diaphragm (4) counter-clockwise and remove with flange (2).
12. Make sure the drain opening (11) is not blocked or soiled. Clean if necessary.
13. Check the safety diaphragm (1) for wear and damage. Replace if necessary.

If nothing indicates that dosing liquid has entered the pump housing, go on as described in section

[7.3.3 Reassembling the diaphragm and valves](#).

Otherwise proceed as described in section

[7.4.2 Dosing liquid in the pump housing](#).

7.3.3 Reassembling the diaphragm and valves

The pump must only be reassembled, if nothing indicates that dosing liquid has entered the pump housing. Otherwise proceed as described in section [7.4.2 Dosing liquid in the pump housing](#).

This section refers to fig. [10](#).

1. Attach flange (2) correctly and screw on new diaphragm (4) clockwise.
 - Make sure that the O-ring (3) is seated correctly!
2. Connect/switch on mains supply.
3. Turn the adjustment knob slowly to bring the diaphragm into its service position "inside" (end of suction phase, diaphragm retracted). Set adjustment knob back to 0 %.
4. Switch off mains supply again.
5. Attach the dosing head (7).
6. Install screws with discs (8) and cross-tighten with a torque wrench.
 - Torque: 4 Nm.
7. Attach the cover (9).
8. Install new valves (5, 6).
 - Do not interchange valves and pay attention to direction of arrow.
9. Connect suction, pressure and deaeration hoses (see section [4.2 Hydraulic connection](#)).

Tighten the dosing head screws with a torque wrench once before commissioning and again after 2-5 operating hours at 4 Nm.

Caution

10. Deaerate dosing pump (see section [5.3 Start and deaerate the pump](#)).

11. Please observe the notes on commissioning in section [5. Startup!](#)

7.4 Diaphragm breakage

If the diaphragm leaks or is broken, dosing liquid escapes from the drain opening (fig. 10, pos. 11) on the dosing head.

In case of diaphragm breakage, the safety diaphragm (fig. 10, pos. 1) protects the pump housing against ingress of dosing liquid.

When dosing crystallising liquids the drain opening can be blocked by crystallisation. If the pump is not taken out of operation immediately, a pressure can build up between the diaphragm (fig. 10, pos. 4) and the safety diaphragm in the flange (fig. 10, pos. 2). The pressure can press dosing liquid through the safety diaphragm into the pump housing.

Most dosing liquids don't cause any danger when entering the pump housing. However a view liquids can cause a chemical reaction with inner parts of the pump. In the worst case, this reaction can produce explosive gases in the pump housing.

Warning

Danger of explosion, if dosing liquid has entered the pump housing!

Operation with damaged diaphragm can lead to dosing liquid entering the pump housing.

In case of diaphragm breakage, immediately separate the pump from the power supply!

Make sure the pump cannot be put back into operation by accident!

Dismantle the dosing head without connecting the pump to the power supply and make sure no dosing liquid has entered the pump housing. Proceed as described in section [7.4.1 Dismantling in case of diaphragm breakage](#).

To avoid any danger resulting from diaphragm breakage, observe the following:

- Perform regular maintenance. See section [7.1 Regular maintenance](#).
- Never operate the pump with blocked or soiled drain opening.
 - If the drain opening is blocked or soiled, proceed as described in section [7.4.1 Dismantling in case of diaphragm breakage](#).
- Never attach a hose to the drain opening. If a hose is attached to the drain opening, it is impossible to recognise escaping dosing liquid.
- Take suitable precautions to prevent harm to health and damage to property from escaping dosing liquid.
- Never operate the pump with damaged or loose dosing head screws.

7.4.1 Dismantling in case of diaphragm breakage

Warning



Danger of explosion, if dosing liquid has entered the pump housing!

Do not connect the pump to the power supply!

This section refers to fig. 10.

1. Make system pressureless.
2. Empty dosing head before maintenance and flush it if necessary.
3. Take suitable steps to ensure that the returning liquid is safely collected.
4. Dismantle suction, pressure and deaeration hose.
5. Remove the cover (9).
6. Loosen screws (8) on the dosing head (7) and remove with discs.
7. Remove the dosing head (7).
8. Unscrew diaphragm (4) counter-clockwise and remove with flange (2).
9. Make sure the drain opening (11) is not blocked or soiled. Clean if necessary.
10. Check the safety diaphragm (1) for wear and damage. Replace if necessary.

If nothing indicates that dosing liquid has entered the pump housing, go on as described in section [7.3.3 Reassembling the diaphragm and valves](#). Otherwise proceed as described in section [7.4.2 Dosing liquid in the pump housing](#).

7.4.2 Dosing liquid in the pump housing

Warning



Danger of explosion!

Immediately separate the pump from the power supply!

Make sure the pump cannot be put back into operation by accident!

If dosing liquid has entered the pump housing:

- Send the pump to Grundfos for repair, following the instructions given in section [7.5 Repairs](#).
- If a repair isn't economically reasonable, dispose of the pump observing the information in section [9. Disposal](#).

7.5 Repairs



Warning

The pump housing must only be opened by personnel authorised by Grundfos!

Repairs must only be carried out by authorised and qualified personnel!

Switch off the pump and disconnect it from the voltage supply before carrying out maintenance work and repairs!

After consulting Grundfos, please send the pump, together with the safety declaration completed by a specialist, to Grundfos. The safety declaration can be found at the end of these instructions. It must be copied, completed and attached to the pump.

The pump must be cleaned prior to dispatch!

Caution

If dosing liquid has possibly entered the pump housing, state that explicitly in the safety declaration! Observe section [7.4 Diaphragm breakage](#).

If the above requirements are not met, Grundfos may refuse to accept delivery of the pump. The shipping costs will be charged to the sender.

8. Faults



8.1 Indication of faults

Depending on the selected operation mode, the pump indicates the following faults with its LEDs:

LED colour	Fault	Remedy
Yellow	low-level signal	<ul style="list-style-type: none"> fill tank check contact type (see section 6.3.4).
Red	empty signal	<ul style="list-style-type: none"> fill tank check contact type (see section 6.3.4).
Red (flashing)	motor blocked	<ul style="list-style-type: none"> reduce backpressure have gear repaired, if necessary.

For further faults, please see [8.2 List of faults](#).

8.2 List of faults

Fault	Possible cause	Possible remedy
Dosing flow too high	Inlet pressure greater than backpressure	Install additional spring-loaded valve (approx. 3 bar) on the discharge side. Increase pressure differential.
	Air in dosing head	Deaerate the pump.
No dosing flow or dosing flow too low	Faulty diaphragm	Change the diaphragm (see section 7.3 Perform service).
	Leakage/fracture in lines	Check and repair lines.
	Valves leaking or blocked	Check and clean valves.
	Valves installed incorrectly	Check that the arrow on the valve housing is pointing in the direction of flow. Check whether all O-rings are installed correctly.
	Blocked suction line	Clean suction line/install filter.
	Suction lift too high	Reduce suction lift. Install priming aid.
	Viscosity too high	Use hose with larger diameter. Install spring-loaded valve on the discharge side.
	Deaeration valve open	Close the deaeration valve.
Irregular dosing	Valves leaking or blocked	Tighten up valves, replace valves if necessary (see section 7.3 Perform service).
	Backpressure fluctuations	Keep backpressure constant.
Liquid escaping from the drain opening on the flange	Faulty diaphragm	Immediately separate the pump from the power supply! Observe section 7. Service and especially section 7.4 Diaphragm breakage .
Liquid escaping	Dosing head screws not tightened	Tighten up screws (see section 4.2 Hydraulic connection).
	Valves not tightened	Tighten up valves/union nuts (see section 4.2 Hydraulic connection).
Pump not sucking in	Suction lift too high	Reduce suction lift; if necessary, provide positive inlet pressure.
	Backpressure too high	Open the deaeration valve.
	Soiled valves	Flush system, replace valves if necessary (see section 7.3 Perform service).

9. Disposal

This product or parts of it must be disposed of in an environmentally sound way. Use appropriate waste collection services. If this is not possible, contact the nearest Grundfos company or service workshop.



Subject to alterations.

Argentina

Bombas GRUNDFOS de Argentina S.A.
Ruta Panamericana km. 37.500 Centro
Industrial Garin
1619 - Garin Pcia. de B.A.
Phone: +54-3327 414 444
Telefax: +54-3327 411 111

Australia

GRUNDFOS Pumps Pty. Ltd.
P.O. Box 2040
Regency Park
South Australia 5942
Phone: +61-8-8461-4611
Telefax: +61-8-8340 0155

Austria

GRUNDFOS Pumpen Vertrieb
Ges. m.b.H.
Grundfosstraße 2
A-5082 Grödig/Salzburg
Tel.: +43-6246-883-0
Telefax: +43-6246-883-30

Belgium

N.V. GRUNDFOS Bellux S.A.
Boomsesteenweg 81-83
B-2630 Aartselaar
Tél.: +32-3-870 7300
Télécopie: +32-3-870 7301

Belarus

Представительство ГРУНДФОС в
Минске
220125, Минск
ул. Шафарнянская, 11, оф. 56
Тел.: +7 (375 17) 286 39 72, 286 39 73
Факс: +7 (375 17) 286 39 71
E-mail: minsk@grundfos.com

Bosnia/Herzegovina

GRUNDFOS Sarajevo
Trg Heroja 16,
BiH-71000 Sarajevo
Phone: +387 33 713 290
Telefax: +387 33 659 079
e-mail: grundfos@bih.net.ba

Brazil

BOMBAS GRUNDFOS DO BRASIL
Av. Humberto de Alencar Castelo
Branco, 630
CEP 09850 - 300
São Bernardo do Campo - SP
Phone: +55-11 4393 5533
Telefax: +55-11 4343 5015

Bulgaria

Grundfos Bulgaria EOOD
Slatina District
Iztochna Tangenta street no. 100
BG - 1592 Sofia
Tel. +359 2 49 22 200
Fax. +359 2 49 22 201
email: bulgaria@grundfos.bg

Canada

GRUNDFOS Canada Inc.
2941 Brighton Road
Oakville, Ontario
L6H 6C9
Phone: +1-905 829 9533
Telefax: +1-905 829 9512

China

**Grundfos Alldos
Dosing & Disinfection**
ALLDOS (Shanghai) Water Technology
Co. Ltd.
West Unit, 1 Floor, No. 2 Building (T 4-2)
278 Jinhui Road, Jin Qiao Export
Processing Zone
Pudong New Area
Shanghai, 201206
Phone: +86 21 5055 1012
Telefax: +86 21 5032 0596
E-mail: grundfosalldos-
CN@grundfos.com

China

GRUNDFOS Pumps (Shanghai) Co. Ltd.
10F The Hub, No. 33 Suhong Road
Minhang District
Shanghai 201106
PRC
Phone: +86-21 6122 5222
Telefax: +86-21 6122 5333

COLOMBIA

GRUNDFOS Colombia S.A.S.
Km 1.5 vía Siberia-Cota Conj. Potrero
Chico,
Parque Empresarial Arcos de Cota Bod.
1A,
Cota, Cundinamarca
Phone: +57(1)-2913444
Telefax: +57(1)-8764586

Croatia

GRUNDFOS CROATIA d.o.o.
Cebini 37, Buzin
HR-10010 Zagreb
Phone: +385 1 6595 400
Telefax: +385 1 6595 499
www.hr.grundfos.com

GRUNDFOS Sales Czechia and

Slovakia s.r.o.
Čapkovského 21
779 00 Olomouc
Phone: +420-585-716 111

Denmark

GRUNDFOS DK A/S
Martin Bachs Vej 3
DK-8850 Bjerringbro
Tlf.: +45-87 50 50 50
Telefax: +45-87 50 51 51
E-mail: info_GDK@grundfos.com
www.grundfos.com/DK

Estonia

GRUNDFOS Pumps Eesti OÜ
Peterburi tee 92G
11415 Tallinn
Tel: + 372 606 1690
Fax: + 372 606 1691

Finland

OY GRUNDFOS Pumput AB
Trukkikuja 1
FI-01360 Vantaa
Phone: +358-(0)207 889 500

France

Pompes GRUNDFOS Distribution S.A.
Parc d'Activités de Chesnes
57, rue de Malacombe
F-38290 St. Quentin Fallavier (Lyon)
Tél.: +33-4 74 82 15 15
Télécopie: +33-4 74 94 10 51

Germany

GRUNDFOS Water Treatment GmbH
Reetzstraße 85
D-76327 Pfinztal (Söllingen)
Tel.: +49 7240 61-0
Telefax: +49 7240 61-177
E-mail: gwt@grundfos.com

Germany

GRUNDFOS GMBH
Schlüterstr. 33
40699 Erkrath
Tel.: +49-(0) 211 929 69-0
Telefax: +49-(0) 211 929 69-3799
E-mail: infoservice@grundfos.de
Service in Deutschland:
E-mail: kundendienst@grundfos.de

Greece

GRUNDFOS Hellas A.E.B.E.
20th km. Athinon-Markopoulou Av.
P.O. Box 71
GR-19002 Peania
Phone: +0030-210-66 83 400
Telefax: +0030-210-66 46 273

Hong Kong

GRUNDFOS Pumps (Hong Kong) Ltd.
Unit 1, Ground floor
Siu Wai Industrial Centre
29-33 Wing Hong Street &
68 King Lam Street, Cheung Sha Wan
Kowloon
Phone: +852-27861706 / 27861741
Telefax: +852-27858664

Hungary

GRUNDFOS Hungária Kft.
Park u. 8
H-2045 Törökbálint,
Phone: +36-23 511 110
Telefax: +36-23 511 111

India

GRUNDFOS Pumps India Private
Limited
118 Old Mahabalipuram Road
Thoraiakkam
Chennai 600 097
Phone: +91-44 4596 6800

Indonesia

PT. GRUNDFOS POMPA
Graha Intirub Lt. 2 & 3
Jln. Ciliilitan Besar No.454. Makasar,
Jakarta Timur
ID-Jakarta 13650
Phone: +62 21-469-51900
Telefax: +62 21-460 6910 / 460 6901

Ireland

GRUNDFOS (Ireland) Ltd.
Unit A, Merrywell Business Park
Ballymount Road Lower
Dublin 12
Phone: +353-1-4089 800
Telefax: +353-1-4089 830

Italy

GRUNDFOS Pompe Italia S.r.l.
Via Gran Sasso 4
I-20060 Truccazzano (Milano)
Tel.: +39-02-95838112
Telefax: +39-02-95309290 / 95838461

Japan

GRUNDFOS Pumps K.K.
1-2-3. Shin-Miyakoda, Kita-tsu
Hamamatsu
431-2103 Japan
Phone: +81 53 428 4760
Telefax: +81 53 428 5005

Korea

GRUNDFOS Pumps Korea Ltd.
6th Floor, Aju Building 679-5
Yeoksam-dong, Kangnam-ku, 135-916
Seoul, Korea
Phone: +82-2-5317 600
Telefax: +82-2-5633 725

Latvia

SIA GRUNDFOS Pumps Latvia
Deglava biznesa centrs
Augusta Deglava ielā 60, LV-1035, Rīga,
Tālr.: + 371 714 9640, 7 149 641
Fakss: + 371 914 9646

Lithuania

GRUNDFOS Pumps UAB
Smolensko g. 6
LT-03201 Vilnius
Tel: + 370 52 395 430
Fax: + 370 52 395 431

Malaysia

GRUNDFOS Pumps Sdn. Bhd.
7 Jalan Peguam U1/25
Glenmarie Industrial Park
40150 Shah Alam
Selangor
Phone: +60-3-5569 2922
Telefax: +60-3-5569 2866

Mexico

Bombas GRUNDFOS de México S.A. de
C.V.
Boulevard TLC No. 15
Parque Industrial Stiva Aeropuerto
Apodaca, N.L. 66600
Phone: +52-81-8144 4000
Telefax: +52-81-8144 4010

Netherlands

GRUNDFOS Netherlands
Veluwezoom 35
1326 AE Almere
Postbus 22015
1302 CA ALMERE
Tel.: +31-88-478 6336
Telefax: +31-88-478 6332
E-mail: info_gnl@grundfos.com

New Zealand

GRUNDFOS Pumps NZ Ltd.
17 Beatrice Tinsley Crescent
North Harbour Industrial Estate
Albany, Auckland
Phone: +64-9-415 3240
Telefax: +64-9-415 3250

Norway

GRUNDFOS Pumper A/S
Strømsveien 344
Postboks 235, Leirdal
N-1011 Oslo
Tlf.: +47-22 90 47 00
Telefax: +47-22 32 21 50

Poland

GRUNDFOS Pompy Sp. z o.o.
ul. Klonowa 23
Baranowo k. Poznań
PL-62-081 Przeźmierowo
Tel: (+48-61) 650 13 00
Fax: (+48-61) 650 13 50

Portugal

Bombas GRUNDFOS Portugal, S.A.
Rua Calvet de Magalhães, 241
Apartado 1079
P-2770-153 Paço de Arcos
Tel.: +351-21-440 76 00
Telefax: +351-21-440 76 90

Romania

GRUNDFOS Pompe Română SRL
Bd. Biruintei, nr 103
Pantelimon county Ilfov
Phone: +40 21 200 4100
Telefax: +40 21 200 4101
E-mail: romania@grundfos.ro

Russia

ООО Грундфос
Школьная, 39-41
Москва, RU-109544, Russia
Тел. (+7) 495 737 30 00, 564 88 00
Факс (+7) 495 737 75 36, 564 88 11
E-mail grundfos.moscow@grundfos.com

Serbia

GRUNDFOS Predstavništvo Beograd
Dr. Milutina Ivkovića 2a/29
YU-11000 Beograd
Phone: +381 11 26 47 877 / 11 26 47
496
Telefax: +381 11 26 48 340

Singapore

GRUNDFOS (Singapore) Pte. Ltd.
25 Jalan Tukang
Singapore 619264
Phone: +65-6681 9688
Telefax: +65-6681 9689

Slovakia

GRUNDFOS s.r.o.
Prievozská 4D
821 09 BRATISLAVA
Phona: +421 2 5020 1426
sk.grundfos.com

Slovenia

GRUNDFOS LJUBLJANA, d.o.o.
Leskoškova 9e, 1122 Ljubljana
Phone: +386 (0) 1 568 06 10
Telefax: +386 (0) 1 568 06 19
E-mail: tehnika-si@grundfos.com

South Africa

Grundfos (PTY) Ltd.
Corner Mountjoy and George Allen
Roads
Wilbart Ext. 2
Bedfordview 2008
Phone: (+27) 11 579 4800
Fax: (+27) 11 455 6066
E-mail: lsmart@grundfos.com

Spain

Bombas GRUNDFOS España S.A.
Camino de la Fuenteclilla, s/n
E-28110 Algete (Madrid)
Tel.: +34-91-848 8800
Telefax: +34-91-628 0465

Sweden

GRUNDFOS AB
(Box 333) Lunnagårdsgatan 6
431 24 Mölndal
Tel.: +46 31 332 23 000
Telefax: +46 31-331 94 60

Switzerland

GRUNDFOS ALLDOS International AG
Schönmattstraße 4
CH-4153 Reinach
Tel.: +41-61-717 5555
Telefax: +41-61-717 5500
E-mail: grundfosalldos-
CH@grundfos.com

Switzerland

GRUNDFOS Pumpen AG
Bruggacherstrasse 10
CH-8117 Fällanden/ZH
Tel.: +41-44-806 8111
Telefax: +41-44-806 8115

Taiwan

GRUNDFOS Pumps (Taiwan) Ltd.
7 Floor, 219 Min-Chuan Road
Taichung, Taiwan, R.O.C.
Phone: +886-4-2305 0868
Telefax: +886-4-2305 0878

Thailand

GRUNDFOS (Thailand) Ltd.
92 Chaloeam Phrakiat Rama 9 Road,
Dokmai, Pravej, Bangkok 10250
Phone: +66-2-725 8999
Telefax: +66-2-725 8998

Turkey

GRUNDFOS POMPA San. ve Tic. Ltd.
Sti.
Gebze Organize Sanayi Bölgesi
İhsan dede Caddesi,
2. yol 200. Sokak No. 204
41490 Gebze/ Kocaeli
Phone: +90 - 262-679 7979
Telefax: +90 - 262-679 7905
E-mail: satis@grundfos.com

Ukraine

Бізнес Центр Європа
Столичне шосе, 103
м. Київ, 03131, Україна
Телефон: (+38 044) 237 04 00
Факс: (+38 044) 237 04 01
E-mail: ukraine@grundfos.com

United Arab Emirates

GRUNDFOS Gulf Distribution
P.O. Box 16768
Jebel Ali Free Zone
Dubai
Phone: +971-4- 8815 166
Telefax: +971-4-8815 136

United Kingdom

GRUNDFOS Pumps Ltd.
Grovebury Road
Leighton Buzzard/Beds. LU7 4TL
Phone: +44-1525-850000
Telefax: +44-1525-850011

U.S.A.

GRUNDFOS Pumps Corporation
17100 West 118th Terrace
Olathe, Kansas 66061
Phone: +1-913-227-3400
Telefax: +1-913-227-3500

Uzbekistan

Grundfos Tashkent, Uzbekistan The
Representative Office of Grundfos
Kazakhstan in Uzbekistan
38a, Oybek street, Tashkent
Телефон: (+998) 71 150 3290 / 71 150
3291
Факс: (+998) 71 150 3292

Addresses revised 07.06.2017

be think innovate

95725839 0817

ECM: 1214328

The name Grundfos, the Grundfos logo, and **be think innovate** are registered trademarks owned by Grundfos Holding A/S or Grundfos A/S, Denmark. All rights reserved worldwide.
© Copyright Grundfos Holding A/S

www.grundfos.com

GRUNDFOS 